

General Description

Series TDA 2/2 way proportional throttle valves are used to control large oil flows.

Features

- Cavity and mounting pattern according to ISO 7368.
- Fail-safe function at power failure.
- Leak-free from port B to A.
- Pressure differential up to 350 Bar (5075 PSI) possible.
- 8 sizes NG16 up to NG100.

Function

The TDA valve has a 3-stage design consisting of the first solenoid operated pilot stage with a spool in sleeve design, the second pilot stage with the control spring and the sequence spool and as main stage the poppet in the sleeve. The proportional solenoid operates the pilot spool against the feedback of the control spring and controls the position of the sequence spool. The main poppet follows the position of the sequence spool and provides an open area for flow from B to A (optional A to B) in proportion to the solenoid current. The poppet is positioned independent of the differential pressure, which can become as high as the maximum working pressure.

In combination with the digital power amplifier PCD00A-400 the valve parameters can be saved, changed and duplicated.

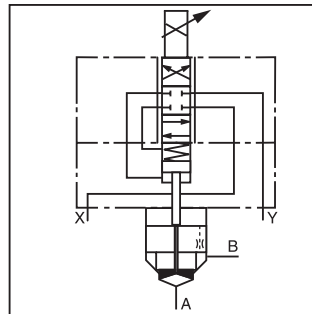

Function Symbol

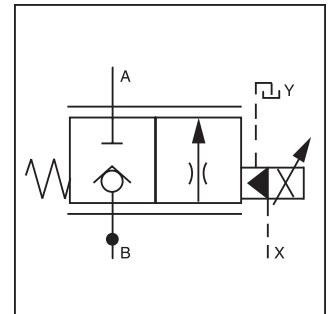

Short Symbol

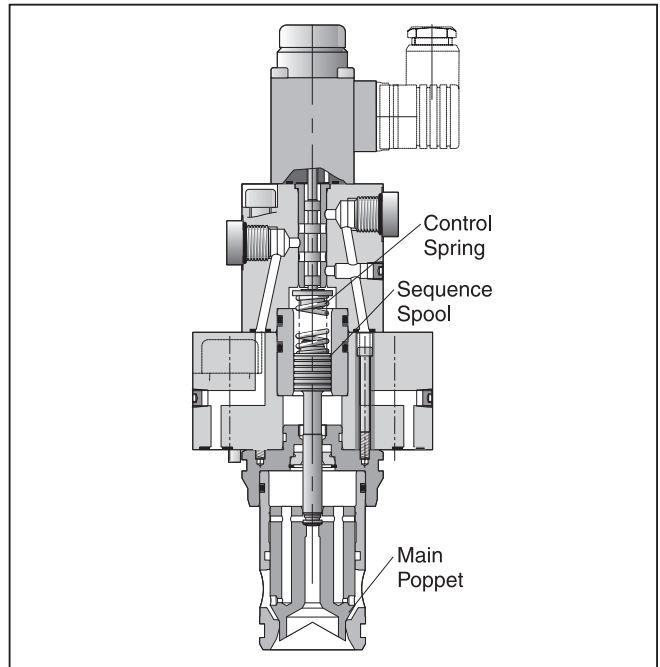

Ordering Information

TDA	□	E	W	0	9	□	2	□	□	□	W	□
Proportional Throttle Valve	Nominal Size	Slip-in Valve ISO 7368	Design	Poppet Shape	Nominal Flow	Flow Direction	Piloting	Seals	Solenoid Voltage	Plug Socket without Plug	Design Series	NOTE: Not required when ordering.

Code	Description
016	NG16
025	NG25
032	NG32
040	NG40
050	NG50
063	NG63
080	NG80
100	NG100

Code	Description
A	A to B
B	B to A

Code	Description
L	6 VDC
X	16 VDC

Code	Description
N	Nitrile
V	Fluorocarbon

Weight:

TDA016	3.1 kg (6.8 lbs.)	TDA050	15.0 kg (33.1 lbs.)
TDA025	4.3 kg (9.5 lbs.)	TDA063	33.0 kg (72.8 lbs.)
TDA032	5.8 kg (12.8 lbs.)	TDA080	63.0 kg (138.9 lbs.)
TDA040	9.2 kg (20.3 lbs.)	TDA100	87.0 kg (191.8 lbs.)

WARNING: This product can expose you to chemicals including Lead, Nickel (Metallic), or 1,3-Butadiene which are known to the State of California to cause cancer, and Lead or 1,3-Butadiene which is known to the State of California to cause birth defects and other reproductive harm. For more information go to www.P65Warnings.ca.gov.

Cat3200_02.indd, ddp, 04/19

General									
Size	NG16	NG25	NG32	NG40	NG50	NG63	NG80	NG100	
Interface	Slip-in cartridge according to ISO 7368								
Mounting Position	Unrestricted								
Ambient Temperature	-20°C to +80°C (-4°F to +176°F)								
Hydraulic									
Maximum Operating Pressure	Ports A, B and X: 350 Bar (5075 PSI), Port Y 10: Bar (145 PSI) maximum								
Nominal Flow $\Delta p = 10$ Bar (145 PSI)	LPM GPM	220 (58)	500 (132)	950 (251)	1400 (370)	2300 (609)	4000 (1058)	6000 (1587)	9500 (2513)
Flow Direction	See Ordering Information								
Fluid	Hydraulic oil according to DIN 51524 ... 525								
Viscosity Recommended	30 to 80 cSt (mm ² /s)								
Viscosity Permitted	20 to 380 cSt (mm ² /s)								
Fluid Temperature	0°C to +60°C (+32°F to +140°F)								
Filtration	ISO 4406 (1999); 18/16/13 (meet NAS 1638:7)								
Minimum Pilot Pressure	> 25% of system pressure								
Minimum Operating Pressure	Port A to B at 10 Bar (145 PSI), B to A at 15 Bar (208 PSI)								
Pilot Oil Supply	Depending on flow direction A or B using X or external X								
Pilot Oil Drain	External using Y, 10 Bar (145 PSI) maximum								
Pilot Oil at $p = 100$ Bar (1450 PSI)	Port X to Y < 1.5 LPM (0.4 GPM)								
Opening Point	At 30% of nominal current								
Manufacturing Tolerance	±5% of Q _{nom}								
Static / Dynamic									
Hysteresis	< 3%								
Repeatability	< 1%								
Response Time $p_x = 50$ Bar (725 PSI)	20 ms	25 ms	30 ms	35 ms	45 ms	55 ms	65 ms	80 ms	
Electrical (Proportional Solenoid)									
Duty Ratio	100% ED								
Protection Class	IP65 in accordance with EN 60529 (plugged and mounted)								
Solenoid	Code	L				X			
	Size	NG16-50	NG25-50	NG32-50	NG40-50	NG63-100	NG80-100	NG100-100	
Solenoid Voltage	6 VDC				16 VDC				
Nominal Current (100% ED)	2.6 amps				1.05 amps				
Nominal Resistance	2.2 Ohm	2.5 Ohm	2.5 Ohm	2.5 Ohm	11.3 Ohm	11.3 Ohm	14 Ohm	14 Ohm	
Power Amplifier Recommended	PCD00A-400								
Solenoid Connection	Connector as per EN 175301-803								

The pilot pressure in X-line must be at least 25% (NG16-40) or 45% (NG50-100) of the pressure in the draining-off line of the cartridge to make sure that the main poppet closes safely without malfunction.

NG16 and NG25 Solenoid Current
 $\Delta P = 10 \text{ Bar (145 PSI)}$

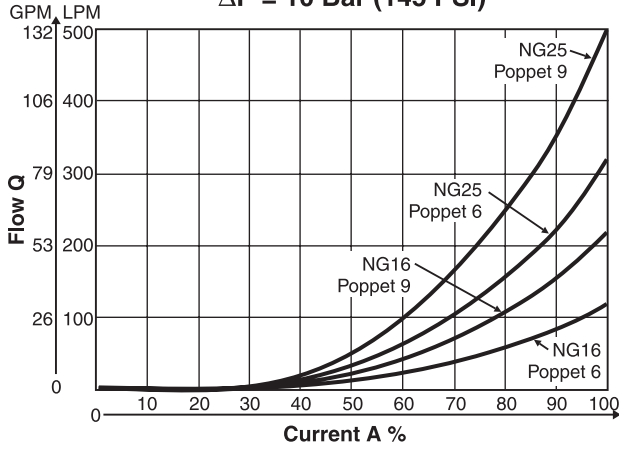

Poppet Stroke / Time

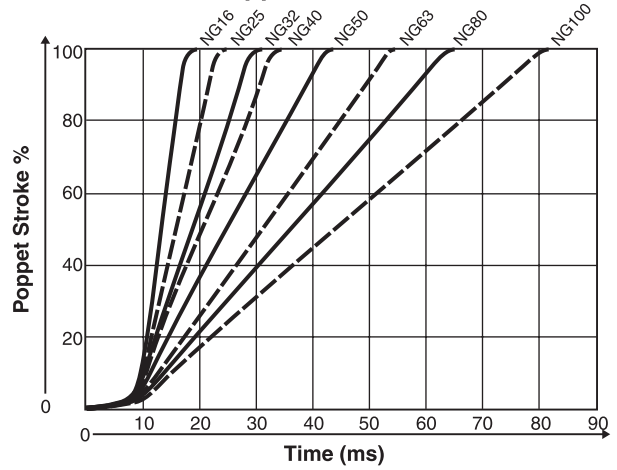

NG32, NG40 and NG50 Solenoid Current
 $\Delta P = 10 \text{ Bar (145 PSI)}$

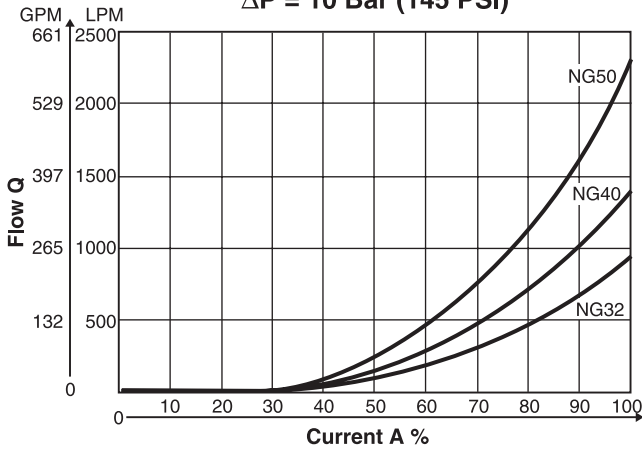

NG63, NG80 and NG100 Solenoid Current
 $\Delta P = 10 \text{ Bar (145 PSI)}$

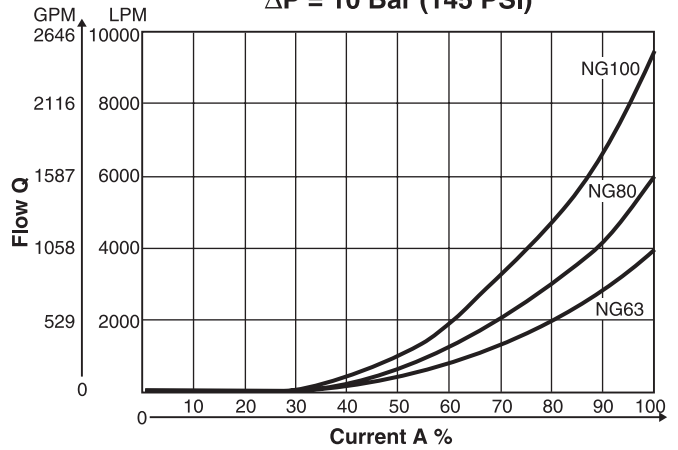

$$\Delta p_{\text{actual}} = \left(\frac{Q_{\text{actual}}}{Q_{\text{nominal}}} \right)^2 \cdot \Delta p_{\text{nominal}}$$

Inch equivalents for millimeter dimensions are shown in (**)

Valves

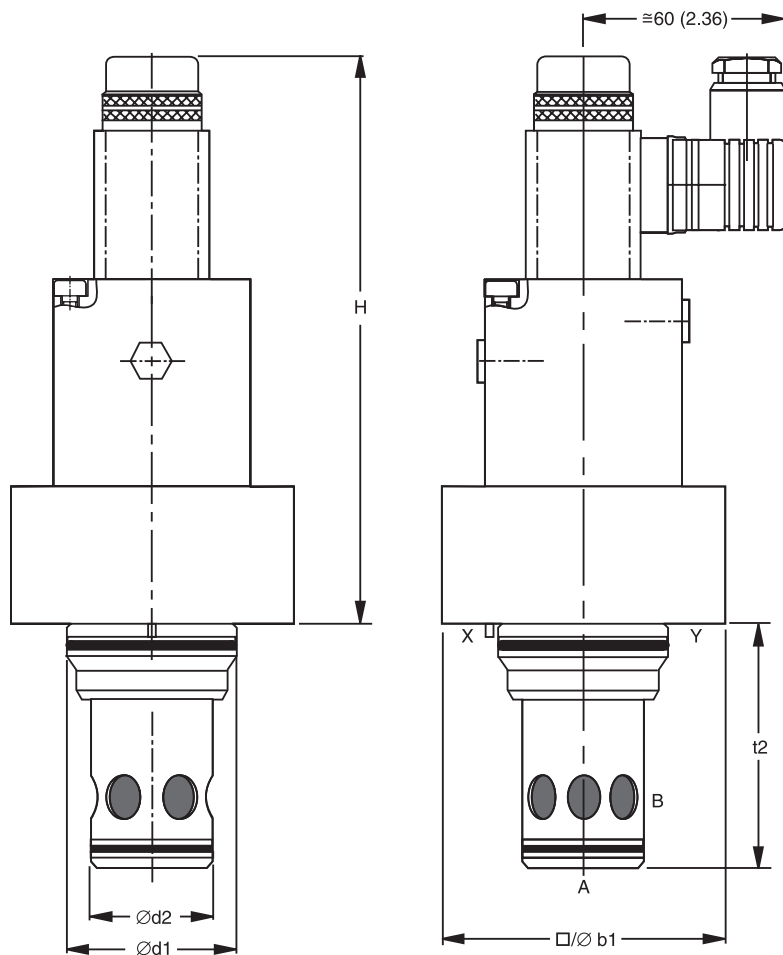

Valve Covers

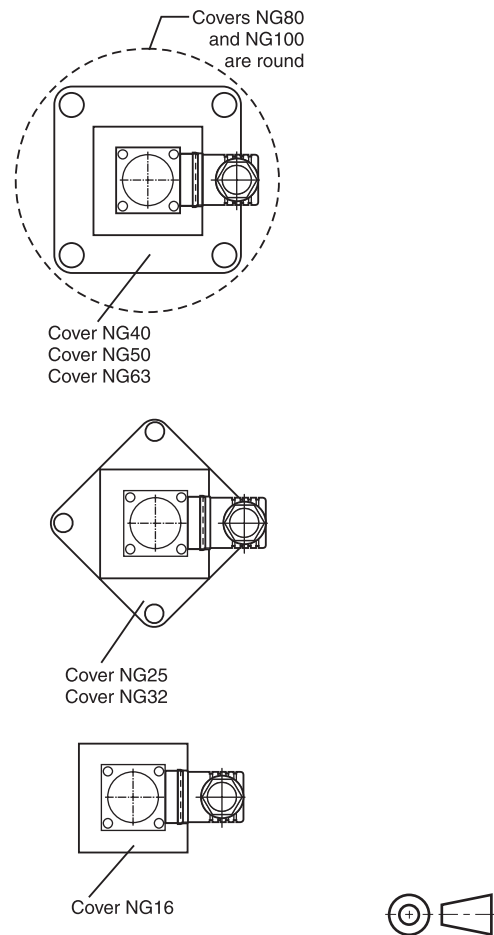

Size	NG16	NG25	NG32	NG40	NG50	NG63	NG80	NG100
H	168.0 (6.61)	173.0 (6.81)	178.0 (7.01)	262.0 (10.31)	198.0 (7.80)	287.0 (11.30)	327.0 (12.87)	342.0 (13.46)
b1	65.0 (2.56)	85.0 (3.35)	102.0 (4.02)	125.0 (4.92)	140.0 (5.51)	180.0 (7.09)	Ø250.0 (9.84)	Ø300.0 (11.81)
d1 ^{H7}	32.0 (1.26)	45.0 (1.77)	60.0 (2.36)	75.0 (2.95)	90.0 (3.54)	120.0 (4.72)	145.0 (5.71)	180.0 (7.09)
d2 ^{H7}	25.0 (0.98)	34.0 (1.34)	45.0 (1.77)	55.0 (2.17)	68.0 (2.68)	90.0 (3.54)	110.0 (4.33)	135.0 (5.31)
t2 ^{+0.1}	56.0 (2.20)	72.0 (2.83)	85.0 (3.35)	105.0 (4.13)	122.0 (4.80)	155.0 (6.10)	205.0 (8.07)	245.0 (9.65)

NG	Bolt Kit -		Kit	
			Nitrile	Fluorocarbon
16	BK-M8x100-4pcs	33 Nm (24.3 lb.-ft.)	SK-TDA016EN20	SK-TDA016EV20
25	BK391 (BK77)	115 Nm (54.8 lb.-ft.)	SK-TDA025EN20	SK-TDA025EV20
32	BK415 (BK85)	281 Nm (207.2 lb.-ft.)	SK-TDA032EN20	SK-TDA032EV20
40	BK416 (BK86)	553 Nm (407.8 lb.-ft.)	SK-TDA040EN20	SK-TDA040EV20
50	BK417 (BK87)	553 Nm (407.8 lb.-ft.)	SK-TDA050EN20	SK-TDA050EV20
63	BK418 (BK88)	1910 Nm (1408.6 lb.-ft.)	SK-TDA063EN20	SK-TDA063EV20
80	BK419 (BK135)	935 Nm (689.6 lb.-ft.)	SK-TDA080EN20	SK-TDA080EV20
100	BK420 (BK90)	1910 Nm (1408.6 lb.-ft.)	SK-TDA100EN20	SK-TDA100EV20